



# CAST RESIN TRANSFORMERS

| [www.uic.com.tw](http://www.uic.com.tw)



ISO 9001 ISO 14001 OHSAS 18001  
UNELECTRA INTERNATIONAL CORP.



# CONTENTS



<b>COMPANY PROFILE .....</b>	<b>1</b>
<b>QUALITY CERTIFICATES .....</b>	<b>2</b>
<b>APPLICATIONS .....</b>	<b>3</b>
<b>CONSTRUCTION .....</b>	<b>4 ~ 5</b>
A. CORE AND FRAME .....	4
B. COIL .....	5
C. TEMPERATURE INDICATOR .....	5
<b>CHARACTERISTICS.....</b>	<b>6</b>
<b>MANUFACTURING FACILITIES.....</b>	<b>7</b>
<b>TESTING FACILITIES .....</b>	<b>7 ~ 9</b>
A. LIGHTNING IMPULSE TEST (BIL).....	8
B. TEMPERATURE RISE TEST .....	8
C. MEASUREMENT OF SOUND LEVEL.....	9
<b>TECHNICAL DATA .....</b>	<b>10 ~ 12</b>
A. TC105F1A-N .....	10
B. TC205F1A-N.....	11
C. TC105F1A-R.....	12
<b>GENERAL CONFIGURATION .....</b>	<b>13</b>



# COMPANY PROFILE



**UIC HEAD OFFICE**

## UNELECTRA INTERNATIONAL CORP.

known as UIC was established by a group of experienced engineers under the direction of Bureau of Industry, Ministry of Economic Affairs, TAIWAN in 1986.

In the beginning UIC introduced state-of-the-art technology and equipment to produce Cast Resin Transformers and secured variety of certificates from well-known third authorities, so the product can be sold well, not only domestically but also internationally.

Due to UIC has focused on the cast resin technique for years, so its extended cast resin related product-Cast Resin Busway was developed and produced since 2000.

The Company hopes to upgrade the domestic and global industry level as well as providing safe and reliable electrical distribution products to the customers.

## QUALITY, SERVICE, CONTRIBUTION

Since the establishment of this Company, "QUALITY, SERVICE and CONTRIBUTION" is our highly honored motto.

Through the implementation of the management concept contains into this motto. UIC assures to offer the EXCELLENT PRODUCTS, SATISFACTORY SERVICE and OUTSTANDING CONTRIBUTION to the customers as the final target.



**UIC FACTORY**

We strive for the best endeavour to provide the gratifying services before and after sales, in-time delivery of our products and reasonable price level. In order to contribute to the society, the company strives to make the products available with high safety, reliability and with full environmental protection sense to our clients as well as community in expectation for the Company to achieve the goal of long lasting operation.

UIC has passed KEMA、TAIPOWER and XIAN、WUHAN、PRC HV LAB. etc. type tests to assure its manufacturing capability and also certified as an ISO 9001 quality assured, ISO 14001 EMS firm and OHSAS 18001 health and safety control. We believe we can offer the best products and service in consonance with our motto "QUALITY、SERVICE、CONTRIBUTION" in operation.



# QUALITY CERTIFICATES



The range of UIC EXICAST® transformer is up to 15MVA and 36kV, As per customers specification or international standards, Such as IEC, NEMA, ANSI, BS, DIN, JIS, AS etc.....

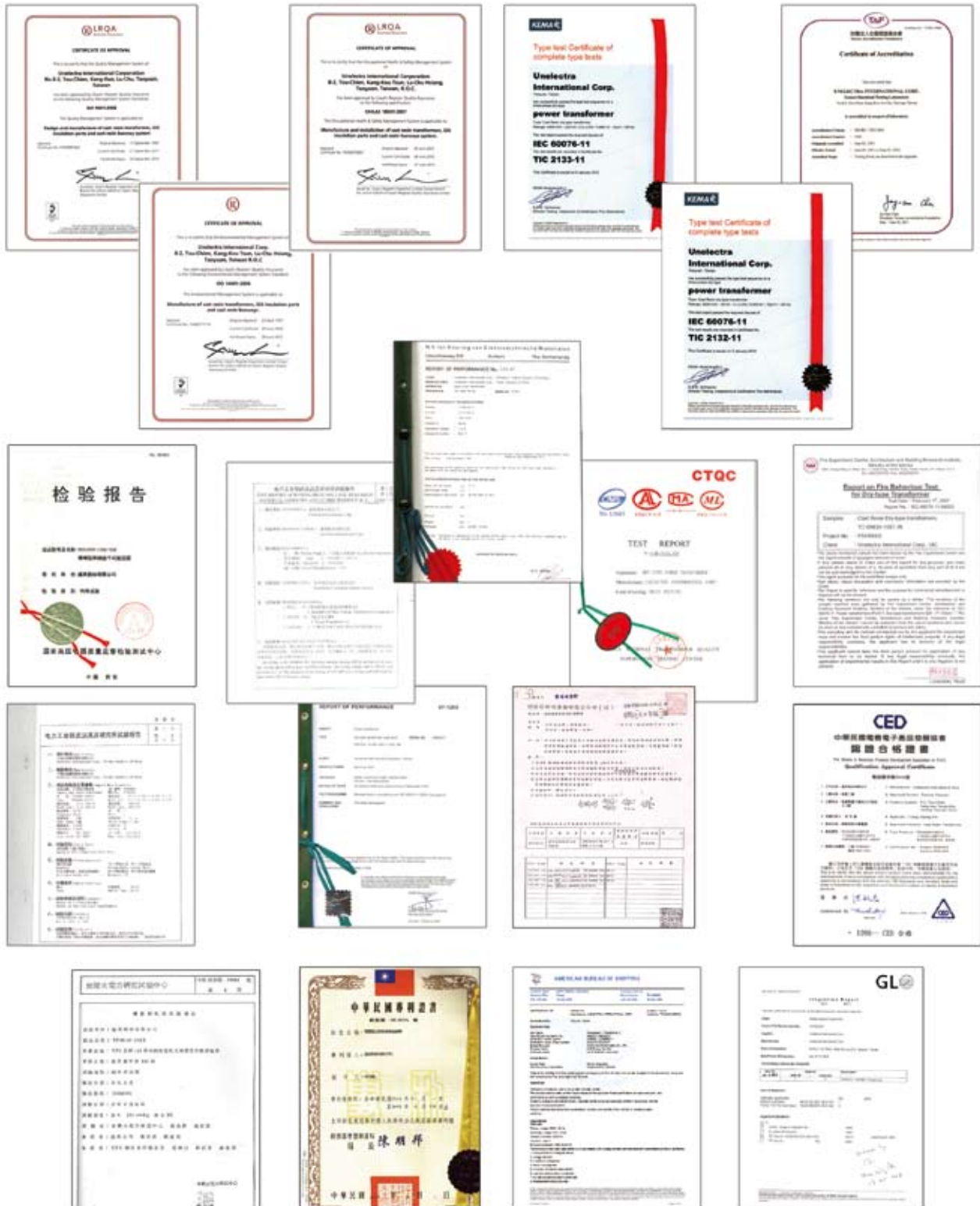



# APPLICATIONS



HIGH SPEED RAIL



MRT SYSTEM



AIRPORT



OIL & GAS PLATFORM



POWER STATION



CONTAINER CRANE

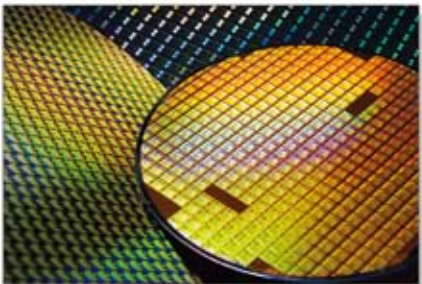

SEMICONDUCTOR INDUSTRY



OPTRONIC INDUSTRY



STEEL INDUSTRY



MALL



HIGH RISE COMMERCIAL BUILDING



HOTEL



MILITARY



HOSPITAL



CAMPUS



# CONSTRUCTION



## A. Core and Frame

The core is made of the highest quality, low loss, cold-rolled, grain-oriented silicon steel with V notch and step lap to reduce no load loss, no load current and noise level to a minimum.

### CORE STRUCTURE & MAGNETIC FLUX at SEAM

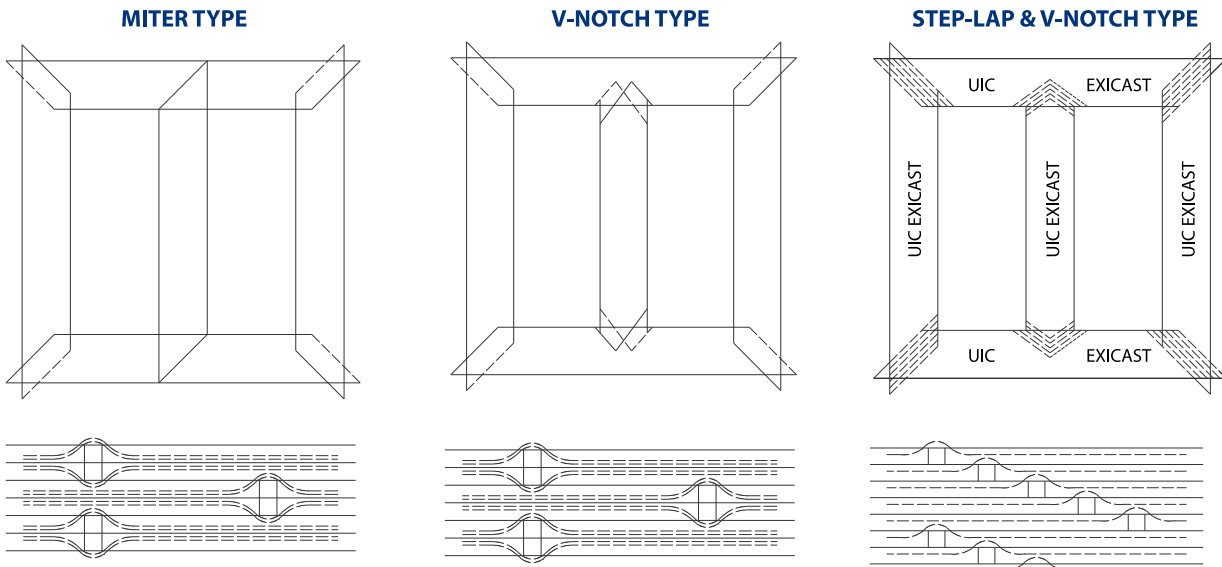

### CORE PROPERTY COMPARE TABLE

Note: assume the base 1.0 on MITER type.

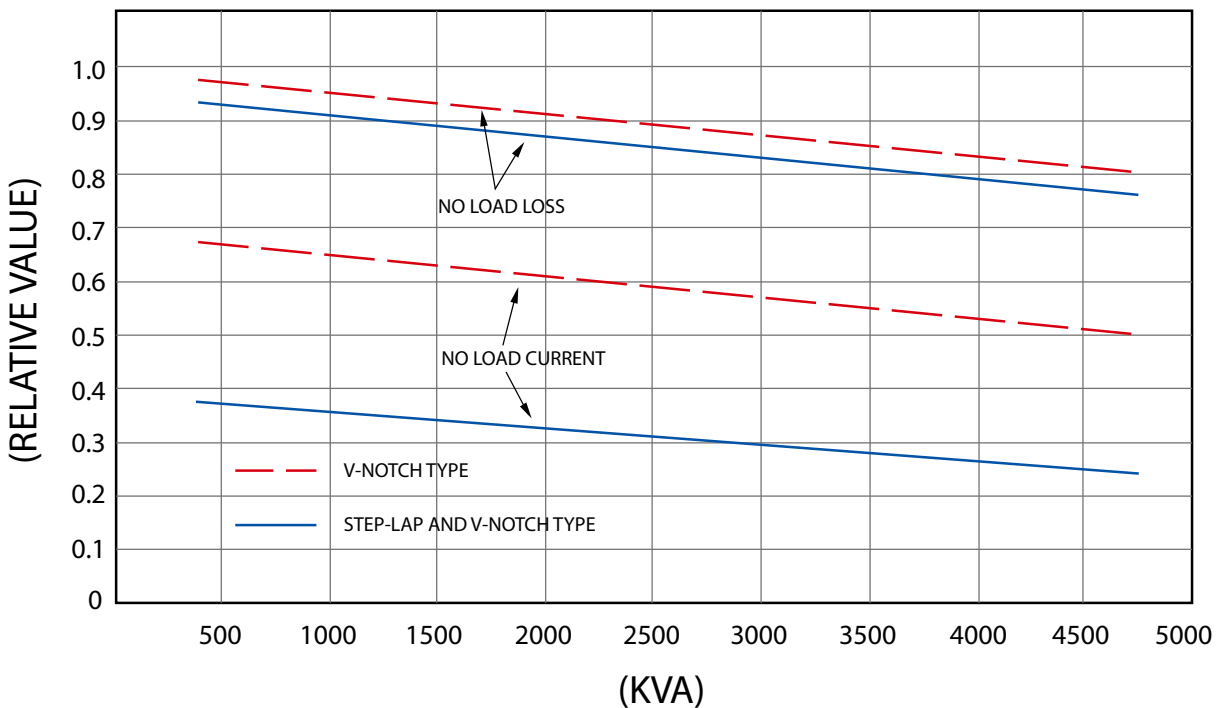



# CONSTRUCTION



## B. Coil

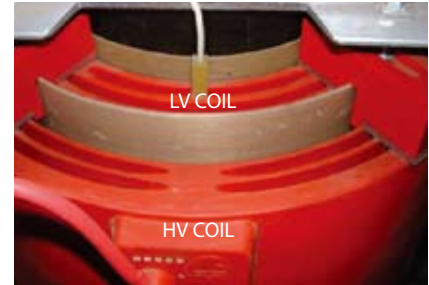
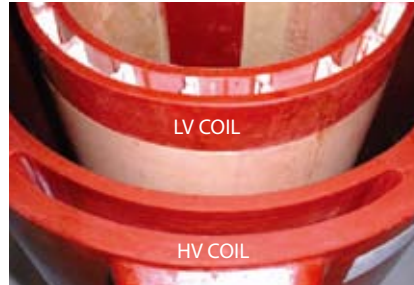

All EXICAST® transformer HV coils are wound on a steel mold and cast in an autoclave under vacuum and controlled the temperature and time with glassfiber reinforced epoxy resin by capillary action in order to avoid voids during the resin impregnation which fully meets the solid cast and epoxy resin encapsulated dry type cast resin transformer requirements.

Resin components, which include resin, hardener and flexibilizer are introduced in the degassing tanks before the mixing for degassing in a thin resin liquid forms. Air bubbles which may exist in resin components are totally eliminated by this continuous degassing process.

The weight of resin components will be automatically weighed by a synchronizing device in the plant that any improper weighing of the components will be exactly avoided.

EXICAST® transformer only adopts copper wire conductor for the HV coils; copper wire, foil or aluminum foil based on customer request for the LV coils. Either HV or LV coils the conductor will be insulated with class F material; coils will belong to "self-extinguishing type".

The components of resin and insulating materials in coils will be non-toxic when burnt.

The coils do not absorb moisture and can be stored at 100% humidity and in temperature down to -40°C while de-energized after which it may immediately be put into full service without need for drying out.

## C. Temperature Indicator



Dial Type Thermometer  
 UIC EXICAST® TR. Standard Accessory  
 Contactor: Alarm & Trip  
 Temperature Range: 0 ~ 200°C  
 Sensor: KO-107



Temperature Indicator  
 Power: 110/220V, 50/60Hz  
 Contactor: Alarm & Trip  
 Temperature Range: -100°C ~ 400°C  
 Sensor: PT-100Ω  
 Protocol(option): RS485/4 ~ 20mA



Temperature Indicator and Controller  
 Power: 110/220V, 50/60Hz  
 Contactor: AF Control, Alarm & Trip  
 Temperature Range: 1°C~199°C  
 Sensor: PT-100Ω x 3  
 Protocol(option): RS485/4~20mA



# CHARACTERISTICS



## Characteristics

### Moisture Proof

EXICAST® TRANSFORMERS is complied with E2 environmental class, so it is suitable to be operated in high humidity, salty or pollution area. And it is capable of being energized directly after a long time storage without drying.



### Short Circuit Resistant

Due to the strong glass fiber reinforced design, the dynamic short circuit strength of EXICAST® TRANSFORMER is superior to the other type transformers.

### High BIL Withstand Level

EXICAST® TRANSFORMERS have impulse levels equal to liquid-immersed transformers. The high BIL withstand can meet international standards or customers' specification.

### Low Noise Level Design

EXICAST® TRANSFORMERS design as per V notch and step lap core construction, the noise level can be reduced, and meet the international standards or some special low noise level requirements.

### Low Partial Discharge

EXICAST® TRANSFORMER is a long life service product. The coils are cast under the vacuum processing to avoid air bubbles and no voids. Each HV coils is tested for partial discharge before and after the assembly for assuring a void-free transformers.

### Maintenance Free

Due to the completely sealed windings have antimoisture property and no oil, it is almost maintenance free during normal operation.

### Fire Resistant

EXICAST® TRANSFORMERS is complied with F1 fire behavior requirements. The safe characteristic of self-extinguishing fire resistance and no noxious material during inflammation can be assured.



### Thermal Shock Resistance

EXICAST® TRANSFORMERS is complied with C2 climate class, using non-filler technology, even the worst temperature fluctuation will not cause the cracking of the coils.



### High Overload Capability

EXICAST® TRANSFORMERS has high thermal time constant of the coils, so it can withstand sudden momentary high overloads better than other type transformers.

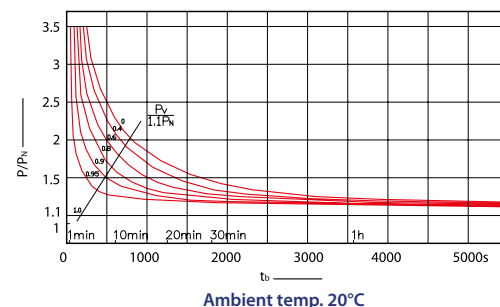
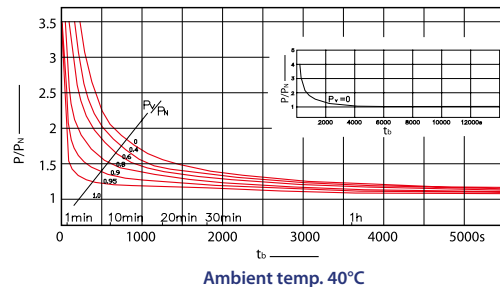





# MANUFACTURING FACILITIES



CORE CUTTING MACHINE



CORE STACKING SET



HV WINDING MACHINE



LV WINDING MACHINE



MOLDS



VACUUM CASTING TANK



# TESTING FACILITIES



## PURPOSE

Each UIC EXICAST transformers must pass factory tests before shipping. The testing procedure is based on ISO 9001, in order to assure that the transformers supplied to the customer will comply with the customer specification and related international standards requirements.

## TEST ITEMS

### Factory tests

- Measurement of winding resistance
- Measurement of voltage ratio
- Check of phase displacement
- Measurement of no-load loss and exciting current
- Measurement of short-circuit impedance and load loss
- Separate-source AC withstand voltage test
- Induced AC withstand voltage test
- Partial discharge Measurements

### Type and special tests (OPTION)

- Lightning Impulse test (BIL)
- Temperature rise test
- Measurement of sound level

## TEST STANDARDS

Following IEC 60076-11 or other standards if specifically specified by the customer.



μΩ METER



TTR



DIGITAL POWER METER



AC VOLTAGE WITHSTAND TEST EQUIP.



INDUCE VOLTAGE TEST SET



P. D. EQUIPMENT



# TESTING FACILITY



## A. LIGHTNING IMPULSE TEST (BIL)

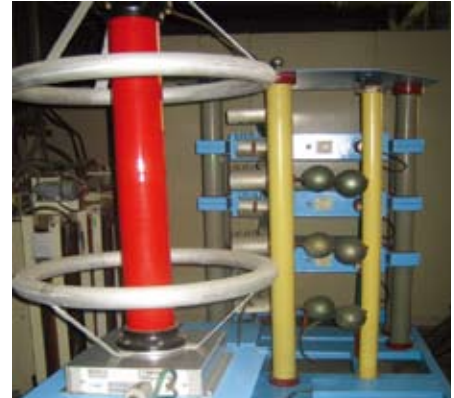
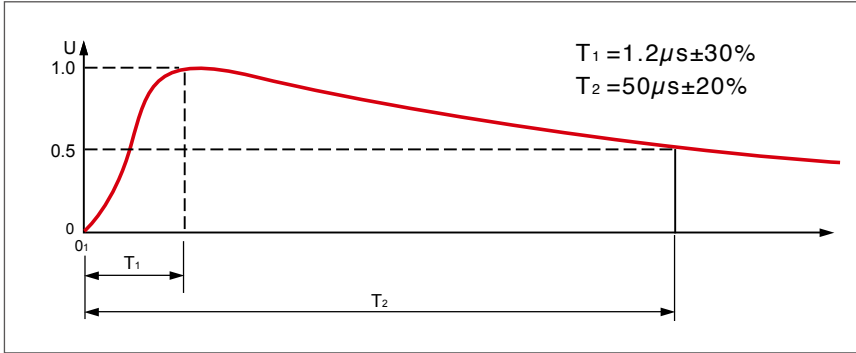

INSULATION LEVELS BASED ON EUROPEAN PRACTICE			
Highest voltage for equipment Um (r.m.s.) kV	Rated short duration separate source AC withstand voltage (r.m.s.) kV	Rated lightning impulse withstand voltage (peak value) kV	
		List 1	List 2 (UIC EXICAST)
≤1.1	3	–	–
3.6	10	20	40
7.2	20	40	60
12	28	60	75
17.5	38	75	95
24	50	95	125
36	70	145	170

## B. TEMPERATURE RISE TEST

WINDING TEMPERATURE RISE LIMITS	
INSULATION SYSTEM TEMPERATURE (°C)	AVERAGE WINDING TEMPERATURE RISE LIMITS AT RATED CURRENT (K)
105 (A)	60
120 (E)	75
130 (B)	80
155 (F)	100
180 (H)	125
200	135
220	150

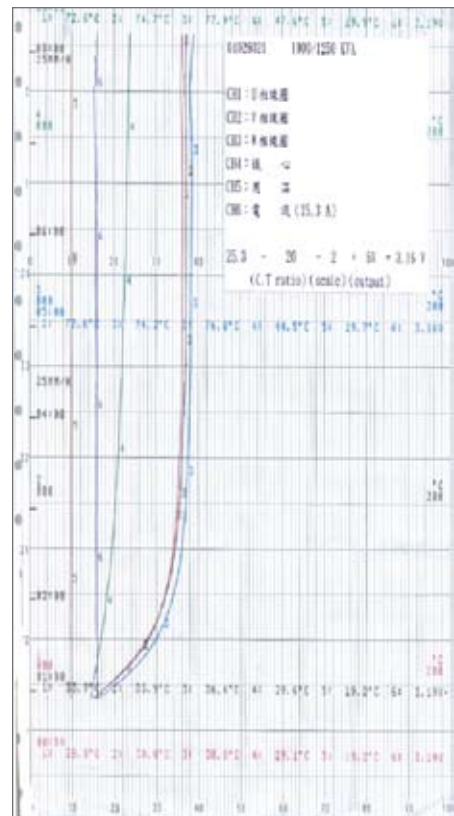

### TEMPERATURE RISE CURVE

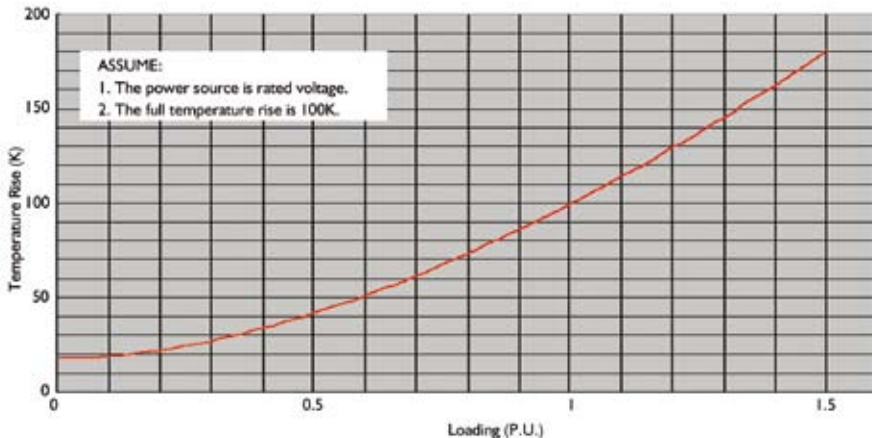



# TESTING FACILITY



## C. MEASUREMENT OF SOUND LEVEL

### MEASUREMENT POINTS

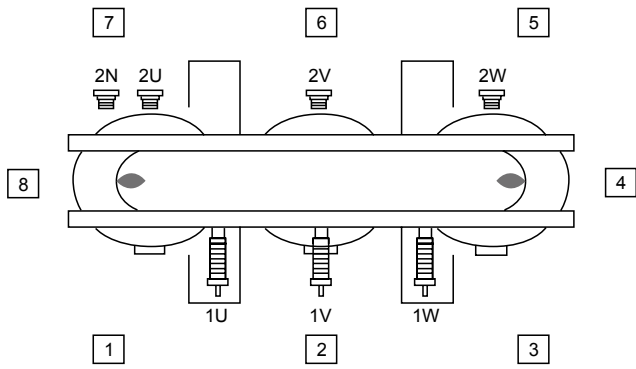

### SOUND SPECTRUM ANALYSIS

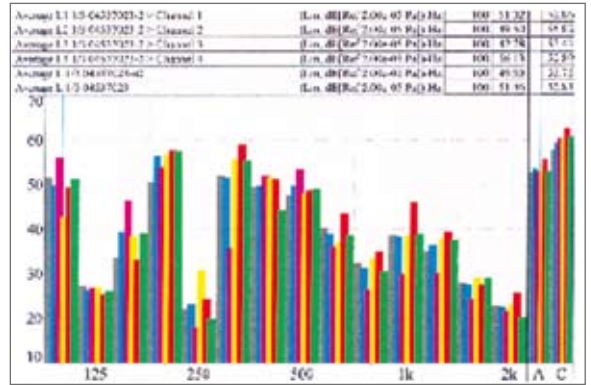

### TESTING CHAMBER





# TECHNICAL DATA



## A. TC105F1A-N

3Ø, 50Hz, Um 12kV, HV BIL 75kV, P.F. 28kV, LV P.F. 3kV, Temperature rise 100K

	500	630	750	800	1000	1250	1500	1600	2000	2500	3000	3150	4000	5000
Rated Power (kVA)	11kV/433V													
No-Load Transformation Ratio	3													
Number of Phases	50 Hz													
Frequency	AN													
Type of Cooling	Dyn11													
Vector Group	1.65T													
Max. Flux Density at Normal Volts, Frequency & Ratio														
No-Load Loss at Rated Volts, Frequency & Normal Tap (W)	1500	1600	1900	1900	2000	2400	2800	3200	3400	4300	4800	5000	6400	8200
Load Loss at Rated Current & Normal Tap at 75°C(W)	6200	8000	9500	9600	10000	11300	12700	13000	14000	17000	20500	21000	25000	31000
Impedance Volts at Normal Ratio & Rated kVA at 75°C (%)	4.0	6.0	6.0	6.0	6.0	6.0	6.0	6.0	6.0	6.0	6.0	6.0	8.0	8.0
● Full Load at p.f. = 1.0	98.48	98.50	98.50	98.58	98.81	98.92	98.98	99.00	99.14	99.16	99.16	99.18	99.22	99.22
● Full Load at p.f. = 0.8	98.11	98.13	98.14	98.23	98.52	98.65	98.72	98.75	98.92	98.85	98.85	98.98	99.03	99.03
● 3/4 Load at p.f. = 1.0	98.69	98.73	98.73	98.80	98.99	99.07	99.12	99.13	99.25	99.27	99.27	99.29	99.32	99.32
● 3/4 Load at p.f. = 0.8	98.36	98.41	98.42	98.50	98.75	98.85	98.91	98.92	99.07	99.08	99.08	99.12	99.15	99.15
● 1/2 Load at p.f. = 1.0	98.79	98.87	98.87	98.94	99.11	99.17	99.21	99.20	99.31	99.32	99.32	99.35	99.37	99.37
● 1/2 Load at p.f. = 0.8	98.50	98.59	98.60	98.67	98.89	98.97	99.01	99.00	99.14	99.15	99.15	99.19	99.22	99.21
Volts Regulation at 75°C (%)	1.31	1.44	1.44	1.37	1.18	1.08	1.02	0.99	0.88	0.86	0.86	0.84	0.94	0.94
● At p.f. = 1.0	3.30	4.61	4.61	4.57	4.44	4.37	4.33	4.31	4.23	4.22	4.22	4.21	5.47	5.46
● At p.f. = 0.8														
Material and Type of Winding	Copper – Wire Winding													
● Primary	Copper – Foil Winding													
● Secondary	100°C													
Max. Temperature Rise of Winding by Resistance	100°C													
● Primary	Class F													
● Secondary	Class F													
Class of Winding Insulation														
● Primary (A/mm <sup>2</sup> )	3-5													
● Secondary (A/mm <sup>2</sup> )	3-5													
Applied Voltage Test (kV)	28													
● Primary	3													
● Secondary	75													
Impulse Voltage Test (BIL) kV	--													
● Primary	Epoxy Resin													
● Secondary	Low-Loss Grain Oriented Silicon Steel													
Insulation Material	Hot-Dipped Galvanized Steel													
● HV & LV Winding	±2 x 2.5%													
● Core Laminations														
● Frame and Other Iron Parts														
Tapping Range														
Neutral Terminal	Yes													
Overall Dimension (IP00)	Length (mm)	1400	1550	1600	1600	1700	1800	1800	1900	1950	2100	2100	2350	2500
● Width (mm)	830	1080	1080	1080	1080	1080	1080	1080	1080	1250	1250	1250	1450	1600
● Height (mm)	1397	1418	1518	1518	1707	1707	1817	1847	1837	1927	2269	2275	2200	2500
Overall Dimension (IP20) (Recommendation)	Length (mm)	1700	1800	1800	2000	2000	2200	2200	2200	2300	2400	2400	2800	2900
● Width (mm)	1300	1400	1400	1500	1500	1500	1500	1500	1500	1550	1600	1600	1600	1800
● Height (mm)	1800	2000	2000	2000	2200	2200	2350	2350	2350	2350	2700	2700	2700	3000
Total Weight (IP00) (kg)	1850	2050	2400	2450	2850	3350	4100	4300	4900	5900	7550	7550	8900	11650
Standard	In accordance to IEC 60076-11 Standard													
Climatic class	C2													
Environmental	E2													
Fire behaviour class	F1													
Partial discharge	≤10pc													



## B. TC205F1A-N

3Ø, 50Hz, Um 24kV, HV BIL 125kV, P.F. 50kV, LV P.F. 3kV, Temperature rise 100K

Rated Power (kVA)	500	630	750	800	1000	1250	1500	1600	2000	2500	3000	3150	4000	5000
No-Load Transformation Ratio	22kV/433V													
Number of Phases	3													
Frequency	50 Hz													
Type of Cooling	AN													
Vector Group	Dyn11													
Max. Flux Density at Normal Volts, Frequency & Ratio	1.65T													
No-Load Loss at Rated Volts, Frequency & Normal Tap (W)	1700	1800	2100	2100	2200	2650	3050	3450	3650	4550	5100	5300	6700	8450
Load Loss at Rated Current & Normal Tap at 75°C (W)	6350	8000	9500	9600	10000	11300	12700	13000	14000	17000	20500	21000	25000	31000
Impedance Volts at Normal Ratio & Rated kVA at 75°C (%)	6.0	6.0	6.0	6.0	6.0	6.0	6.0	6.0	6.0	6.0	6.0	6.0	6.0	8.0
Full Load at p.f. = 1.0	98.42	98.47	98.48	98.56	98.79	98.90	98.96	98.98	99.13	99.15	99.15	99.17	99.21	99.22
Full Load at p.f. = 0.8	98.03	98.09	98.10	98.20	98.50	98.62	98.70	98.73	98.91	98.93	98.94	98.97	99.02	99.02
3/4 Load at p.f. = 1.0	98.61	98.68	98.69	98.77	98.97	99.05	99.10	99.11	99.24	99.25	99.27	99.28	99.31	99.31
3/4 Load at p.f. = 0.8	98.27	98.36	98.37	98.46	98.71	98.81	98.88	98.89	99.05	99.07	99.08	99.10	99.14	99.14
1/2 Load at p.f. = 1.0	98.70	98.81	98.82	98.89	99.07	99.13	99.18	99.17	99.29	99.30	99.32	99.33	99.36	99.36
1/2 Load at p.f. = 0.8	98.38	98.51	98.53	98.61	98.84	98.92	98.97	98.96	99.11	99.13	99.16	99.17	99.20	99.20
At p.f. = 1.0	1.44	1.44	1.44	1.37	1.18	1.08	1.02	0.99	0.88	0.86	0.86	0.84	0.94	0.94
At p.f. = 0.8	4.61	4.61	4.61	4.57	4.44	4.37	4.33	4.31	4.23	4.22	4.22	4.21	5.47	5.46
Material and Type of Winding	Copper – Wire Winding													
Primary	Copper – Foil Winding													
Secondary	100°C													
Primary	100°C													
Secondary	Class F													
Primary	Class F													
Secondary	4.0													
Primary (A/mm <sup>2</sup> )	4.0													
Secondary (A/mm <sup>2</sup> )	50													
Applied Voltage Test (kV)	3													
Primary	125													
Secondary	--													
Impulse Voltage Test (BIL) kV	Epoxy Resin													
Insulation Material	Low-Loss Grain Oriented Silicon Steel													
Frame and Other Iron Parts	Hot-Dipped Galvanized Steel													
Tapping Range	±2 x 2.5%													
Neutral Terminal	Yes													
Overall Dimension (IP00)	Length (mm)	1450	1600	1650	1650	1850	1850	1850	1850	1950	2000	2150	2400	2550
Width (mm)	830	1080	1080	1080	1080	1080	1080	1080	1080	1080	1250	1250	1450	1600
Height (mm)	1367	1478	1578	1578	1767	1837	1877	1907	1897	1987	2329	2357	2400	2650
Overall Dimension (IP20)	Length (mm)	1800	1800	1800	2000	2000	2200	2200	2300	2300	2500	2500	2800	2900
Width (mm)	1400	1400	1400	1500	1500	1500	1500	1500	1550	1550	1600	1600	1600	1800
Height (mm)	1700	2000	2000	2200	2200	2350	2350	2350	2350	2350	2700	2700	2700	3200
Total Weight (IP00) (kg)	1800	2200	2600	2600	3000	3650	4100	4500	5100	6100	7750	7750	9150	11900
Standard	In accordance to IEC 60076-11 Standard													
Climatic class	C2													
Environmental	E2													
Fire behaviour class	F1													
Partial discharge	≤10pc													



# TECHNICAL DATA



## C.TC105F1A-R

3Ø, 50Hz, Um 12kV, HV BIL 75kV, P.F. 28kV, LV P.F. 3kV, Temperature rise 100K (HIGH EFFICIENCY)

Rated Power (kVA)	500	630	750	800	1000	1250	1500	1600	2000	2500	3000	3150	4000	5000
No-Load Transformation Ratio	11kV/433V													
Number of Phases	3													
Frequency	50 Hz													
Type of Cooling	AN													
Vector Group	Dyn11													
Max. Flux Density at Normal Volts, Frequency & Ratio	1.65T													
No-Load Loss at Rated Volts, Frequency & Normal Tap (W)	820	1250	1450	1450	1600	1900	2300	2300	2850	3350	4300	4400	5600	6100
Load Loss at Rated Current & Normal Tap at 75°C(W)	5300	5450	5000	5000	6100	7500	8800	8800	12000	13900	19600	20700	21400	27100
Impedance Volts at Normal Ratio & Rated kVA at 75°C(%)	6.0	6.0	6.0	6.0	6.0	6.0	6.0	6.0	6.0	6.0	8.0	8.0	8.0	8.0
Full Load at p.f. = 1.0	98.79	98.95	99.15	99.20	99.24	99.25	99.31	99.31	99.26	99.31	99.21	99.21	99.33	99.34
Full Load at p.f. = 0.8	98.49	98.69	98.94	99.00	99.05	99.07	99.08	99.14	99.08	99.14	99.01	99.01	99.18	99.18
3/4 Load at p.f. = 1.0	99.00	99.09	99.25	99.29	99.33	99.35	99.36	99.40	99.36	99.41	99.32	99.33	99.43	99.43
3/4 Load at p.f. = 0.8	98.75	98.87	99.06	99.12	99.17	99.19	99.20	99.25	99.21	99.26	99.16	99.16	99.29	99.29
1/2 Load at p.f. = 1.0	99.15	99.18	99.29	99.33	99.38	99.40	99.40	99.44	99.42	99.46	99.39	99.40	99.46	99.49
1/2 Load at p.f. = 0.8	98.94	98.97	99.11	99.16	99.22	99.25	99.26	99.30	99.27	99.32	99.24	99.25	99.33	99.36
At p.f. = 1.0	1.23	1.04	0.84	0.80	0.79	0.78	0.76	0.73	0.78	0.73	0.97	0.97	0.84	0.86
At p.f. = 0.8	4.47	4.34	4.21	4.18	4.17	4.16	4.15	4.12	4.16	4.13	5.49	5.49	5.39	5.41
Material and Type of Winding	Copper – Wire Winding													
Primary	Copper – Foil Winding													
Secondary	100°C													
Max. Temperature Rise of Winding by Resistance	100°C													
Primary	Class F													
Secondary	Class F													
Class of Winding Insulation	Class F													
Max. Current Density at Rated Load	3.5													
Primary	3.5													
Secondary	28													
Applied Voltage Test (kV)	3													
Primary	75													
Secondary	--													
Impulse Voltage Test (BL) kV	Epoxy Resin													
Primary	Low-Loss Grain Oriented Silicon Steel													
Secondary	Hot-Dipped Galvanized Steel													
Insulation Material	±2 x 2.5%													
Core Laminations	Yes													
Frame and Other Iron Parts	No													
Tapping Range	Yes													
Neutral Terminal	Yes													
Length (mm)	1400	1550	1550	1550	1600	1600	1700	1700	1900	1950	2150	2150	2350	2350
Width (mm)	830	830	1080	1080	1080	1080	1080	1080	1250	1250	1250	1250	1450	1450
Height (mm)	1420	1660	1690	1690	1710	1750	1890	1990	1920	2180	2190	2200	2200	2360
Overall Dimension (IP00)	1700	1800	1800	1800	2000	2000	2000	2000	2000	2300	2500	2500	2800	2800
Length (mm)	1300	1300	1400	1400	1500	1500	1550	1550	1550	1550	1600	1600	1600	1600
Width (mm)	1800	2100	2100	2100	2200	2200	2400	2400	2400	2600	2600	2600	2700	2900
Height (mm)	1900	2300	2900	3000	3350	3800	4650	4900	5500	6800	7900	7900	9400	11000
Total Weight (IP00) (kg)	58	60	60	60	60	60	61	61	61	62	63	63	65	66
Noise Level dB(A)	In accordance to IEC 60076-11 Standard													
Standard	C2													
Climatic class	E2													
Environmental	F1													
Fire behaviour class	≤10pc													
Partial discharge	≤10pc													



# GENERAL CONFIGURATION

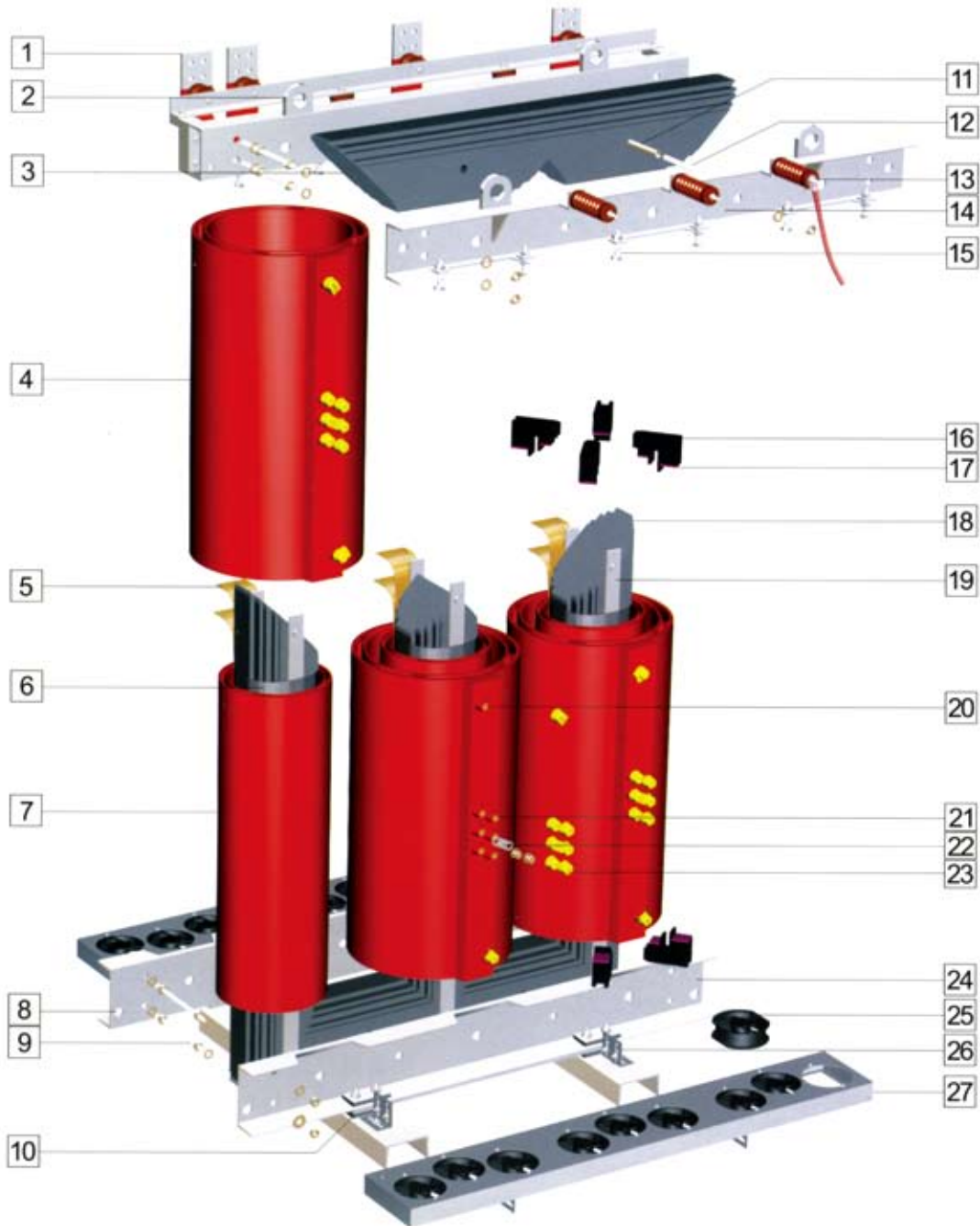

- 1. LV Terminals
- 2. Lifting Lugs
- 3. Core Yoke
- 4. HV Coil
- 5. LV Coil Termination
- 6. Core Bandage
- 7. LV Coil

- 8. Towing Holes
- 9. Frame Bolts
- 10. Anti-Vibration Pad
- 11. Clamp Bolt Insulation
- 12. Clamp Bolts
- 13. HV Insulators
- 14. Upper Frame

- 15. Core Clamp Adjuster
- 16. Coil Support Block
- 17. Resilient Pad
- 18. Core Leg
- 19. Tie Bars
- 20. HV Coil Terminal
- 21. HV Tapping

- 22. Tapping Link
- 23. Tapping Cover
- 24. Lower Frame
- 25. Cooling Fan
- 26. Fan Supporters
- 27. Cooling Fan Set



## UNELECTRA INTERNATIONAL CORP.

### ■ HEAD OFFICE

12F, 66, CHUNG-CHENG ROAD, SHIN-  
CHUANG, NEW TAIPEI 24243, TAIWAN  
TEL: +886-2-8994-4025  
FAX: +886-2-8994-0422

### ■ FACTORY

NO. 8-2, TOU-CHIEH, KANG-KOU,  
LU-CHU, TAOYUAN 33842, TAIWAN  
TEL: +886-3-324-4301  
FAX: +886-3-324-4850