

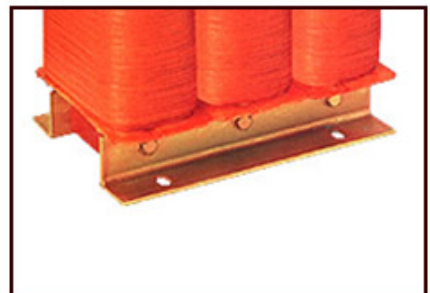

AsiaElectricTechnologies

ZAT series

Motor Starting Auto-Transformers

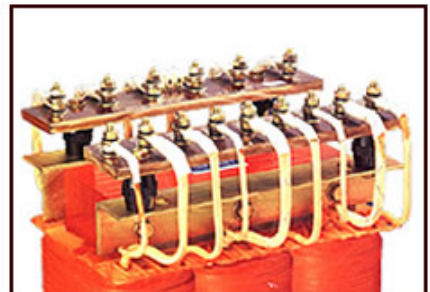
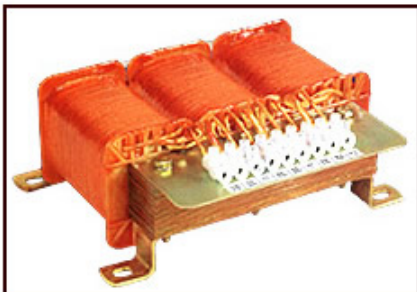

Auto Transformers
For Heavy Duty Starting

Catalogue no. AET-ZAT-2013-11

AET-ZAT-2013-11: Page 1

Design Overview

AET ZAT series Motor Starting Auto Transformer with fixed tapings are used in Auto Transformer type of starters to reduce the voltage across the motor terminals while starting. This reduced voltage limits the in rush current and lessen the strain on driven machinery while starting the motor. For the same value of line current drawn during the starting period motors with auto transformer type starters deliver the maximum starting torque when compared to other type of starters.

Iron core

- ❑ Uses high quality E.I laminated silicon steel processed from state of the art modern punching facilities.

Windings

- ❑ High quality enameled copper wires of 1 PEW and EIW grades withstand temperatures up to 155°C and 180°C respectively.
- ❑ High temperature tolerant fiberglass boards are used as bobbins to separate the core and windings.
- ❑ Sized, transposed and shaped to minimize Eddy current losses.
- ❑ Fully impregnated with class H varnish and oven dried.

Finishing

- ❑ Uses high quality polyester varnish for good bonding and high dielectric strength, which reduces, electrical leakage and noise.

Mounting Design

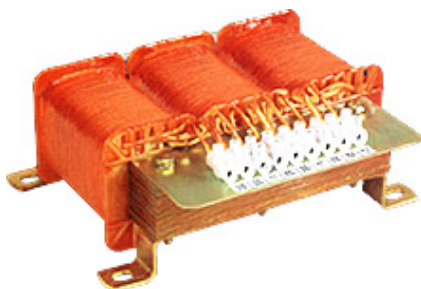

Type 1 - Wall Mount with connectors



Type 2 - Wall Mount with terminal blocks

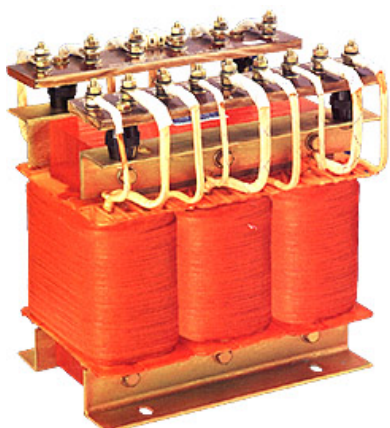

Type 3 - Floor Stand with bolts and nuts

Standards

In accordance with standards:

- IEC 60726 Dry Type Transformers
- Conforming to European Union standards, EN 61558

Technical Specifications

Rating

Low Tension Motor Starting Auto Transformer

- 3 Phase : 200V to 440V
- Capacity : 3.75kW up to 1000Kw

High Tension Motor Starting Auto Transformer

- 3 Phase : 3.3kV to 11kV
- Capacity : 200kW up to 2000kW

Tapping

- Capacity: 3.75kW ~ 11.00 kW - Single Tapping @ 70%
- Capacity: 11.00kW ~ 45.00 kW - Three Tapping @ 50%, 60%, 75%
- Capacity: 56.00kW ~ 200kW - Three Tapping @ 50%, 65%, 80%

Duty Ratings

Maximum restart frequency 8 times per hour with even intervals.
Within 5 seconds to maximum of 15 seconds depend on application.

Insulation Class

- 1 PEW - 155°C polyester enameled copper wire.
- EIW - 180°C polyester enameled copper wire.

Protection

Normally closed contact thermostat embedded in the coil for over temperature sensing.

Cooling

Natural air cool.

Termination

- Capacity: 3.75kW ~ 11.00 kW - High quality fire retardant grade connectors
- Capacity: 11.00kW ~ 112.00 kW - High quality fire retardant polyamide terminal blocks
- Capacity: 135.00kW ~ 200kW - Chromed steel bolt & nuts



ZAT series Motor Starting Auto-Transformers

AsiaElectricTechnologies

Technical Data – 5 HP – 75HP

Rated power (KW)	3.75	5.5	7.5	11	11	15	22	30	37.5	45
Rated Power (HP)	5	7.5	10	15	15	20	30	40	50	60
Thermostat	0/1	0/1	0/1	0/1	1	1	1	1	1	1
Tapping	1	1	1	1	4	4	4	4	4	4
Tapping Percentage	70%	70%	70%	70%	50% 60% 75%	50% 60% 75%	50% 60% 75%	50% 60% 75%	50% 60% 75%	50% 60% 75%
Weight (Kg)	6	7	8	13	13	14	16	18	20	24
Test Voltage										
Max ambient temperature(°C)	40									

Technical Data – 100HP – 600HP

Rated power (KW)	56	66	75	94	112	135	150	185	209	
Rated Power (HP)	75	88	100	125	150	180	200	250	280	
Thermostat	0/1	0/1	0/1	0/1	1	0/1	1	1	1	
Tapping	2.5kV for 1 min									
	3	3	3	3	3	3	3	3	3	
Tapping Percentage	50% 65% 80%	50% 65% 80%	50% 65% 80%	50% 65% 80%	50% 65% 80%	50% 65% 80%	50% 65% 80%	50% 65% 80%	50% 65% 80%	50% 65% 80%
Weight (Kg)	37	42	45	52	60	70	87	90	100	
Test Voltage										
Max ambient temperature(°C)	40									

Non-standard ratings available upon request

Dimensions and weights

KW	HP	A	B	C	D	E	F	Mounting	Terminal	WEIGHT (KG)
3.75	5	195	210	90	-	182	120	WM	connector	6
5.5	7.5	195	210	90	-	182	120	WM	connector	7
7.5	10	195	210	95	-	182	120	WM	connector	8
11	15 (S/T)	220	235	95	-	205	140	WM	connector	13
11	15 (3/T)	225	235	130	-	205	140	WM	Terminal Block	13
15	20	225	235	135	-	205	140	WM	Terminal Block	14
22	30	250	255	145	-	228	158	WM	Terminal Block	16
30	40	250	255	150	-	228	158	WM	Terminal Block	18
37.5	50	250	255	155	-	228	158	WM	Terminal Block	20
45	60	270	280	165	-	247	178	WM	Terminal Block	24
56	75	270	280	180	-	247	178	WM	Terminal Block	37
66	88	330	380	210	-	247	178	WM	Terminal Block	42
75	100	330	380	210	-	283	211	WM	Terminal Block	45
94	125	330	380	220	-	283	211	WM	Terminal Block	52
112	150	330	380	230	-	283	211	WM	Terminal Block	60
135	180	340	340	215	250	270	160	FS	Bolts & Nuts	70
150	200	340	345	213	300	270	170	FS	Bolts & Nuts	87
185	250	370	395	205	275	310	170	FS	Bolts & Nuts	90
209	280	370	395	215	285	310	180	FS	Bolts & Nuts	100

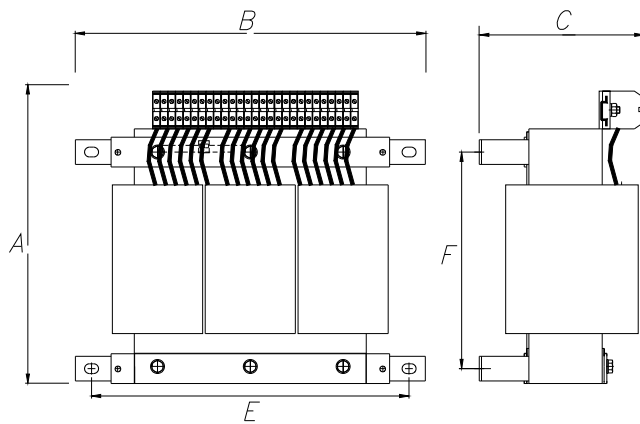

WM: Wall Mounting

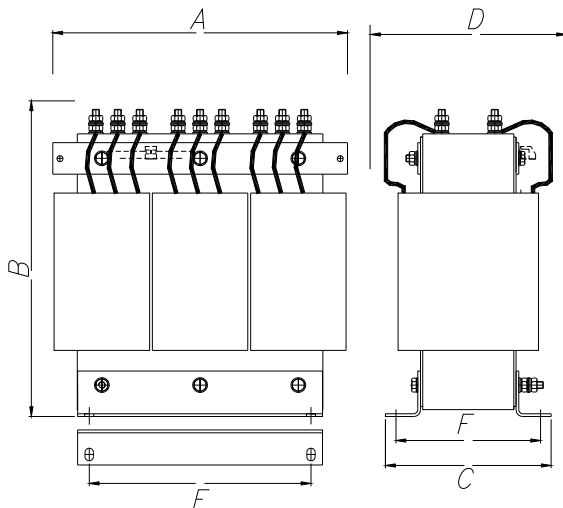

FS: Floor Standing